

IN THE VANGUARD OF AUDIO TECHNOLOGY



Yamaha
Natural Sound
Separate Components





YAMAHA

POWER

NATURAL SOUND STEREO CONTROL AMPLIFIER C-70

PHONES

LOW

HIGH

PARAMETRIC TONE CONTROL

FILTER

AUX

REC. OUT

PHONO

BALANCE

ON

AUDIO MUTE

DISC DIRECT

OFF

TONE

TAPES

TAPES

AUX 1

AUX 2

PHONO

TUNER

VOLUME

0

10

20

30

40

50

60

70

80

90

100



Behind the Superior Yamaha Sound

*Yamaha top-line
separate amplifiers*

are ranked among the most prestigious components produced throughout the world.

Yamaha separate components offer performance, control versatility and reliability that equals, and usually exceeds, that of the most advanced competitive units available.

Yamaha's care and attention to detail, coupled with our awesome technological capabilities produce audio components that are unmatched by any other manufacturer.

One of the primary reasons behind our remarkable success in the audio field is

Yamaha's vast musical experience and human sensitivity gained through almost a century of crafting many of the world's finest music instruments – from grand pianos to piccolos.

Much of the sophisticated analog and digital electronic technology developed for Yamaha's highly respected contemporary music instruments and professional sound reinforcement equipment further contributes to the advancement and improvement of Yamaha home audio components.

In addition, since all the necessary research, technical and production facilities are maintained internally, Yamaha can thoroughly guarantee the overall quality of every audio product.

And there is much more to the Yamaha audio success story.

Every new Yamaha product must face a formidable challenge in proving its music reproduction accuracy: the critical ears of Yamaha music instrument designers and renowned acoustic specialists.

Yamaha Control Amplifiers: Setting New Standards

BEHIND YAMAHA'S SUPERIOR PERFORMANCE

The Preamplifier as a Link in the Audio Chain

Excluding transducers such as cartridges and speakers, an audio preamplifier is the most critical element in any audio chain due to its extremely large influence over final sound quality. There are two basic reasons for the preamplifier's position of importance:

1. The preamplifier deals primarily with low-level input sources such as the output from phono cartridges and tape decks, so any noise or distortion present in the system will have a large overall effect on these tiny signals.

2. Any signal rerouting such as input selection and tape monitoring functions, as well as sound control functions such as tone control and equalization, must be built into the preamplifier. This requires extreme care in planning and design to ensure optimum sound performance as well as maximum control versatility and ease of operation. As stated in reason 1, even the slightest amount of noise or distortion inherent in the preamplifier system will have a large effect on sound reproduction quality due to the proportionately large degree of non-linearity (distortion and noise) compared to the actual size of the audio signal itself. Minimizing non-linearity in the preamplifier means that critical attention must be paid not only to circuit design and layout, but to choosing and even producing individual amplifier components that have the lowest possible inherent non-linearity. This is where Yamaha's extensive internal semiconductor development and production facilities pay off in a big way when it comes to achieving the ultimate in audio reproduction accuracy. Reason 2 demands extensive know-how in the fields of acoustics, human engineering and circuit design, as well as a thorough understanding of the needs of the audio enthusiast. Acoustic technology comes into play in determining the type and range of sound control required, human engineering places the right controls in the right locations with just the right-size switches and knobs



for the easiest, most error-free operation, while advanced circuit design ensures that no features are added that will detract from the sound reproduction quality of the preamplifier, and that the features that are added will provide optimum performance and benefit to the user. Finally, Yamaha's thorough understanding of your listening needs—under actual listening conditions—means that you'll have precisely the right amount of control at your fingertips to get the very best sound possible in any acoustic environment, under any listening conditions. Obviously, producing a superior audio preamplifier is no small matter. Yamaha's many past successes in this area are proof of the vast, uncompromised technology and musical sensitivity we put behind every preamplifier we make.

Yamaha Preamplifier Firsts

Yamaha has a long, distinguished history of "firsts" in the sound reproduction field. Several of these involve notable innovations in audio preamplifiers. The now-famous C-1 control amplifier was, for example, the very first preamplifier in the world to offer an all-FET sound reproduction system—literally from input to output—when teamed up with its matching all-FET B-1 power amplifier. This unique component combination achieved a giant step forward in music reproduction accuracy. The C-2 and C-2a preamplifiers have been long praised by the most critical audiophiles for their incredibly natural sound reproduction and simplified, uncluttered control format. The C-4 preamplifier introduced the first tone control system with con-

tinuously variable bass and treble control turnover frequencies, while the C-6 was the first preamp ever to incorporate a true two-band parametric equalizer system. At Yamaha, the innovations never stop. In the new C-70 and C-50 preamplifiers we've incorporated all the technology and know-how gained through past experience, as well as a considerable amount of fresh, new technology and innovative features that are sure to make these fine new preamplifiers outstanding members in the ongoing lineup of Yamaha audio firsts.

TOP-PERFORMANCE TECHNOLOGY IN THE NEW C-70 & C-50 CONTROL AMPLIFIERS

Both the C-70 and C-50 offer a vast array of new technology and advanced features designed specifically to give you more music reproduction accuracy and more control over the response you hear in your particular listening environment. Sophisticated sound-oriented technology includes the New Linear Transfer circuit. The New Linear Transfer circuit effectively minimizes the current distortion inherent in class-A amplification stages by continuously adjusting the output stage transistor bias so that the transistors' most linear gm region always corresponds with the audio signal

New Linear Transfer Circuit

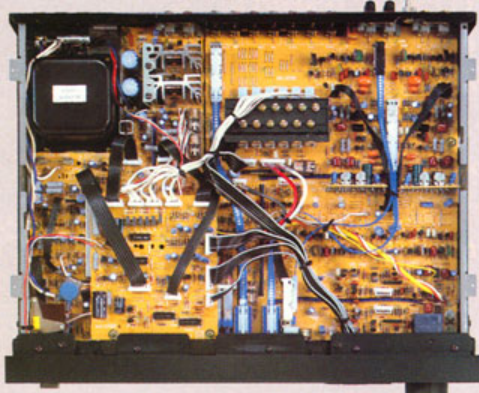
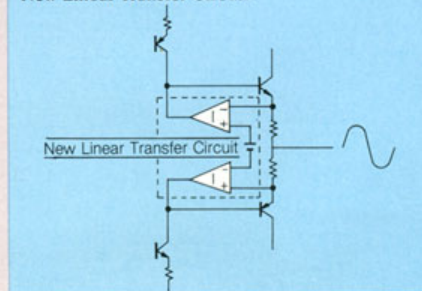

C-70 Interior



C-50

being processed. This audio breakthrough ensures that the entire preamplifier circuit—from input to output—operates at optimum

Control Amplifier Quality Parts

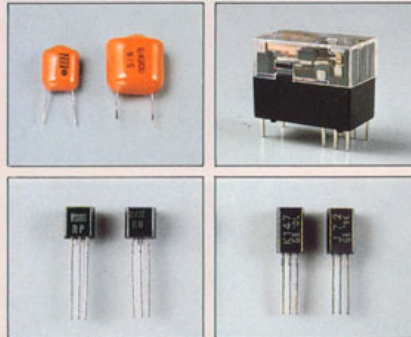

ERE Principal

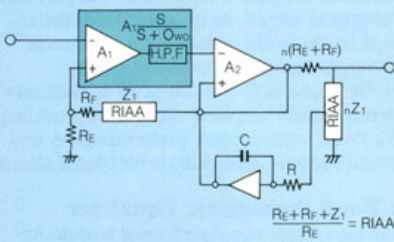

$$\frac{R_E + R_F + Z_1}{R_E} = \text{RIAA}$$

ERE (2 kHz)

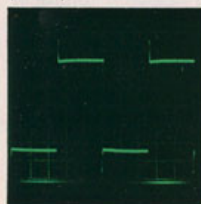

Conventional Equalizer (2 kHz)

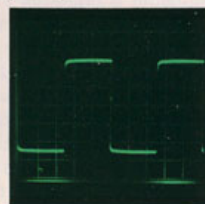

performance levels at all times, no matter what type of input signal is being processed. Another new performance-boosting feature

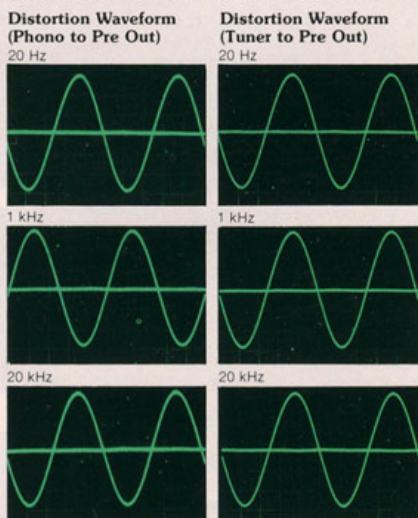

offered in both these fine pre-amplifiers is the ERE (Extended Rolloff Equalizer) phono equalizer; a unique design that obviates the conventional sound degrading instability of standard RIAA phono equalizers at high frequencies. This highly advanced equalizer offers the ultimate in disc reproduction precision by permitting perfectly accurate RIAA equalization up to 100 kHz. As for sound control convenience, both the C-70 and C-50 offer "tone" control systems that actually give you the capability of adjusting overall response to provide the most accurate subjective tonal response in your

own listening environment—something that conventional tone control systems simply cannot do with any degree of accuracy. In the C-50 you get continuously variable turn-over frequencies for the bass and treble controls, while the C-70 provides a full professional-quality parametric equalizer system with which you can perform exacting response compensation. All in all, the C-70 and C-50 hold a lot of surprises—even for the critical, seasoned audiophile. And each and every surprise is guaranteed to be a pleasant one.

C-70 / C-50 Optional EIA Standard Rack Mount Adaptors



Tone Control Characteristics (Level Control)

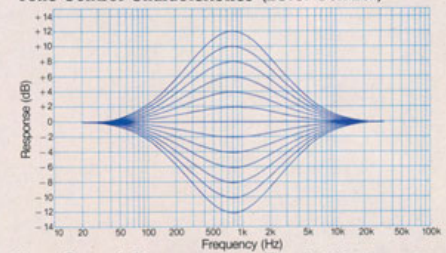

Tone Control Characteristics (Bandwidth Control)

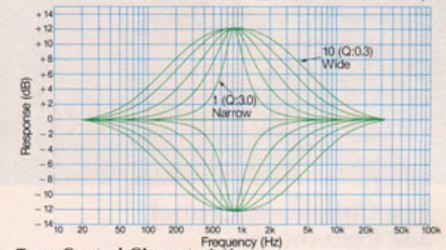

Tone Control Characteristics (Center Frequency Control)

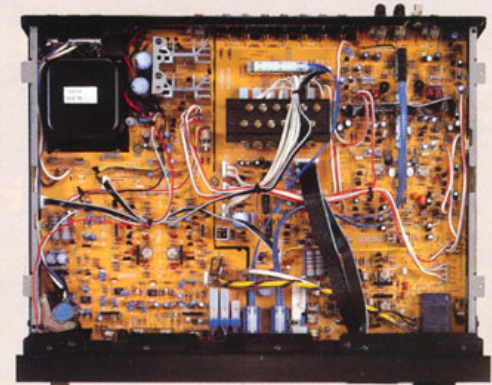
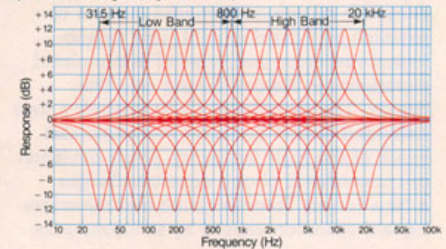

C-50 Interior

C-70 Natural Sound Stereo Control Amplifier



The Ultimate in Control and Performance

The Yamaha C-70 Stereo Control Amplifier reflects an immense amount of research and development, vast technological resources and years of accumulated experience in Natural Sound amplifier design. The remarkable C-70 features a new Extended Rolloff Equalizer that eliminates much of the high-frequency phase deviation of conventional phono equalizer designs, a New Linear Transfer circuit that minimizes current distortion caused by semiconductor



non-linearity in class-A amplification stages, completely independent preamplifier stages for moving magnet and moving coil cartridges ensuring the best possible performance with each type, a unique Varigain volume control system that completely obviates the problems associated with conventional attenuator-type volume controls, a full two-band parametric equalizer for precise response tailoring, and a unique inverted output feature that makes it easy to set up a number of top-performance reproduction systems. In addition to all these advanced performance and versatility oriented features, the C-70 features the most exacting, highest-quality design and construction throughout. Careful attention has been paid to the smallest details,

like making sure that the connector terminals are non-magnetic, in addition to being gold-plated, so magnetic fields generated by the audio signal in the connector terminals cannot affect sound quality. In the Yamaha C-70 you get a sophisticated stereo control amplifier capable of providing the finest reproduction performance in any sound system — even fully professional setups.

2-Band Parametric Equalizer

The parametric equalizer format is undoubtedly the most comprehensive, precise means of tonal response tailoring available today. Although it is a fairly recent development in the sound reproduction field, the parametric equalizer is preferred for response control in the world's most sophisticated professional recording studios. The reason for the parametric equalizer's popularity in professional circles is that, unlike previous equalizer systems, it provides independent, continuously variable control over frequency, bandwidth and level. That is, you can set any center frequency for a range of frequencies you

Block Diagram

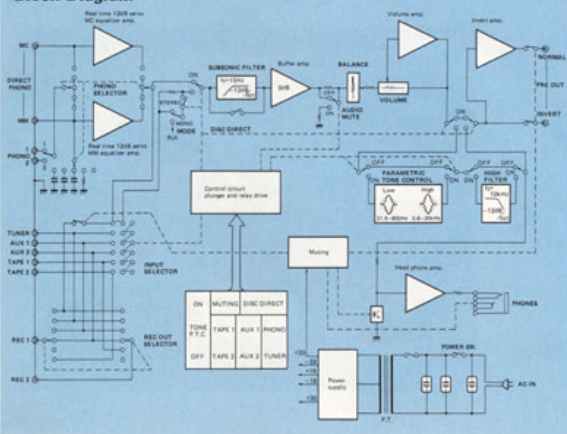

need to equalize, you can set the bandwidth to precisely cover the frequency range to be equalized, and, like conventional equalizer systems, you can precisely set the desired amount of boost or cut in the frequency range determined by the frequency and bandwidth controls (BANDWIDTH is called "Q" in some professional parametric equalizer systems). The parametric equalizer system

Parametric Equalizer

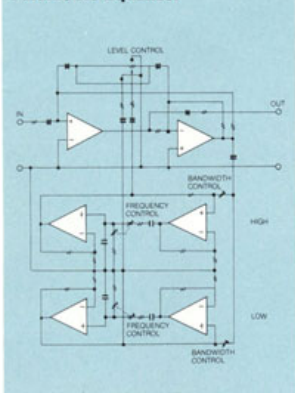

provided in the C-70 gives you the same type of response tailoring flexibility offered by professional systems. Two bands of equalization are provided: one which covers a frequency range of

from 31.5 Hz to 800 Hz, and the other with a frequency range of 800 Hz to 20 kHz. You have continuously variable control over the bandwidth of each frequency band ($Q = 0.3 - 3$), and ± 12 dB boost/cut control in each band.

This equalizer system gives you incredibly broad control over reproduction response, letting you create precisely the response you need for the most accurate music reproduction in any listening environment.

Varigain Volume Control

The volume controls used in conventional amplifiers are "attenuators". This means that they perform their volume reduction function by shunting an appropriate amount of the audio signal to ground. Unfortunately, this type of volume control has a number of limitations in terms of achieving optimum sound reproduction quality:

C-70 Varigain Volume Control Square-Wave Response (10 kHz) vs **Conventional Amplifier Square-Wave Response (10 kHz)**

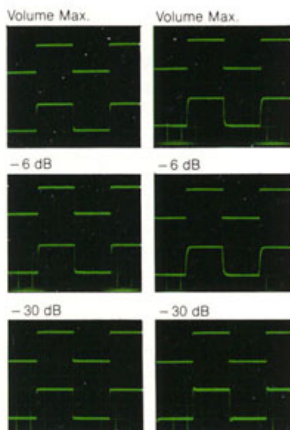

1. Volume reduction generally reduces *only* the level of the audio signal, leaving the amplifier's residual noise to obliterate musical detail when listening at low volume (the Yamaha four-gang volume control used in the C-50 eliminates this problem).

2. Using a potentiometer to shunt portions of the audio signal to ground results in mid-circuit impedance variations that can affect response and distortion characteristics. The Yamaha Varigain volume control system overcomes the above problems by actually varying the gain of the amplifier to control volume instead of bleeding off a portion of the music signal. Since the gain of the amplifier is reduced to lower volume, the

Varigain Volume Control Attenuation vs. Noise Level

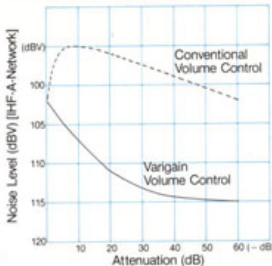

amplifier's residual noise is naturally reduced, while at the same time maintaining the highest possible signal-to-noise ratio at all volume levels. Further, the Varigain system produces no impedance variations so distortion and response characteristics are optimum at all volume settings. Although this seems to be a relatively obvious improvement in amplifier design, it took Yamaha ingenuity and attention to detail to implement the Varigain volume control for your listening pleasure.

New Linear Transfer Circuit

Although push-pull class-A-bias amplification stages offer overall reproduction accuracy greater than class B configurations, conventional versions of this circuit suffer from current distortion due to the fact that the "gm" (mutual transconductance) curve of any semiconductor is distinctively non-linear outside its ideal flattest portion. Signals falling outside the transistors' flattest gm range become distorted. Yamaha engineers found a way to minimize this type of distortion in the New Linear Transfer circuit. This advanced circuit adjusts the bias to the class-A stage semiconductors according to the size of the input audio signal, thereby ensuring that the semiconductors' linear gm range always corresponds to the audio signal being processed. This means that an absolute minimum of current distortion is assured with any input signal. In the C-70, all amplification stages from the phono equalizer to the output stage feature the Yamaha New Linear Transfer system.

ERE (Extended Rolloff Equalizer)

With the vast improvements in overall amplifier performance, the time has come to provide an RIAA equalizer capable of equally fine performance. Today's low-level flat-response amplifiers easily achieve virtually distortion-free response up to 100 kHz or more. Conventional RIAA equalizer amplifiers, however, come nowhere near this outstanding performance. The Yamaha Extended Rolloff Equalizer meets the modern performance standards by eliminating phase variation beyond the range where conven-

tional equalizers begin to deviate from the RIAA curve. This type of extended equalizer accuracy was previously impossible to achieve because of high-frequency instability limitations. The Yamaha ERE completely eliminates this instability while providing an accurately extended high-frequency curve, permitting greater reproduction precision than has ever been possible. The ERE circuit further incorporates a built-in 12-dB/oct subsonic filter that makes clean, unmuddied reproduction possible down to a low 10 Hz. The Yamaha ERE circuit makes a difference in phono reproduction that you can hear. And it's a difference you'll really appreciate because you'll discover nuances and subtleties in the music on your favorite records that you may never have heard before.

Inverting Preamplifier Outputs

This highly original Yamaha feature gives you incredible flexibility in planning and setting up a true "audiophile class" sound reproduction system. Used in conjunction with the C-70's standard non-inverting outputs let you use two stereo power amplifiers—one for each channel—to achieve pro-class power output and sound quality; you can couple the left and right channels to your power amp in inverse phase, and reverse the phasing of your speakers to increase power efficiency and achieve incredibly natural bass reproduction. You can experiment to find the system that is just right for your listening needs. Whether you end up with one of the advanced systems described here, or a standard component setup, the C-70 guarantees you the finest, most "live" music reproduction performance available.



Direct Phono Inputs

For the purest, most natural disc reproduction performance, the C-70 provides input terminals for moving magnet and moving coil cartridges that feed directly to their respective head/EQ amplifiers without being routed through the phono 1/2 switch as are the PHONO 1 and 2 inputs. This means that switch contact resistance in this critical low-level high-gain stage cannot affect disc reproduction quality.

Other Features

- *Selectable MM cartridge load capacitance
- *Rec Out selector
- *Disc Direct function
- *Solenoid/relay function switching
- *Dual AUX terminals
- *Flip-down control cover
- *Switchable 10 kHz high filter
- *Switchable 15 Hz subsonic filter
- *Phono 1/2 selector
- *Stereo/Mono mode selector
- *Optional EIA rack mount adaptors

C-50 Natural Sound Stereo Control Amplifier



Uncompromised Circuit and Function Engineering

The C-50 Stereo Control Amplifier features an impressive array of unique circuit innovations that are specifically designed to give you more accurate, natural music reproduction. In addition to straightforward, sensible circuit design from input to output, the C-50 features a brand new ERE (Extended Rolloff Equalizer) circuit that eliminates the high-frequency phase deviation inherent in conventional RIAA equalizer designs, New Linear Transfer circuitry for an absolute



minimum of current distortion caused by semiconductor non-linearity in push-pull class-A amplification stages, and DC configuration circuitry throughout for the highest accuracy in waveform transmission.

If you're seriously interested in putting together a truly high-performance separate component audio system, the C-50 is one preamplifier you should definitely hear before making your final choice—your ears will tell you more than we can ever describe in words.

Moreover, each and every individual circuit component has been carefully chosen for optimum characteristics so there is virtually no chance of sound quality degradation due to less-than-ideal or mismatched components. Functionally, the C-50 provides extensive response tailoring flexibility with continuously variable bass and treble control turnover frequencies. And, like any Yamaha component, all controls give you complete control over the most critical parameters that affect your listening pleasure.

Continuously Variable Tone Control Turnover Frequencies

Tone controls are provided in a preamplifier to allow the listener to roughly compensate for acoustic deficiencies in his listening room, as well as for unbalanced program source response, and, simply, to create an overall tonal balance that he finds "pleasant." The control range provided by most tone control systems, however, is severely limited since the bass and treble control turnover frequencies are usually arbitrarily determined and preset by the manufacturer. Some more advanced tone control systems approach this problem by permitting two or three-position switching of the tone control turnover frequencies. The Yamaha C-50 goes even

Block Diagram

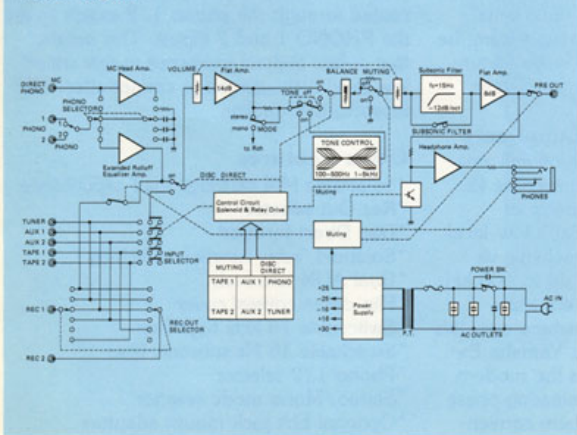

further by permitting continuously variable control of the bass and treble tone control turnover frequencies over a conveniently wide range. Bass control turnover can be varied continuously from 100 Hz to 500 Hz, and treble control turnover can be varied between 1 kHz and 5 kHz, permitting extensive response control for the most accurate tonal compensation in any listening situation.

Direct MC Cartridge Input Capability

Today's moving coil (MC) phono cartridges offer sound reproduction quality with considerably greater detail and clarity than their moving magnet (MM) counterparts. MC cartridge output level, however, is too low to be fed directly to most phono equalizer amplifiers, requiring an extra stage of amplification in the form of a step-up transformer or pre-preamplifier.

Simply setting the C-50 phono selector to "MC" permits *direct* input of MC cartridges without the need for a separate step-up device. Phono input sensitivity and impedance characteristics are automatically switched for optimum performance with high-quality MC cartridges such as the Yamaha MC-1X/1S, MC-3, MC-5, MC-7 or MC-9.

New Linear Transfer Circuit

Although push-pull class-A-bias amplification stages offer overall reproduction accuracy greater than class B configurations, conventional versions of this circuit suffer from current distortion due to the fact that the "gm" (mutual transconductance) curve of any semiconductor is distinctively non-linear outside its ideal flattest portion.

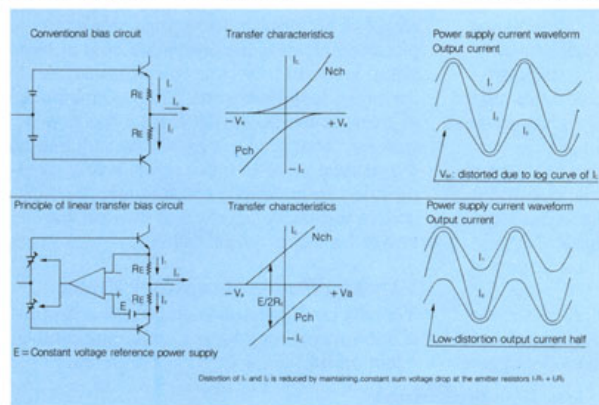

Signals falling outside the transistors' flattest gm range become distorted. Yamaha engineers found a way to minimize this type of distortion in the New Linear Transfer circuit. This advanced circuit adjusts the bias to the class-A stage semiconductors according to the size of the input audio signal, thereby ensuring that the semiconductors' linear gm range always corresponds to the audio signal being processed. This means that an absolute minimum of current distortion is assured with any input signal. In the C-50, all amplification stages from the

phono equalizer to the output stage feature the Yamaha New Linear Transfer system.

Distortion Waveform with New Linear Transfer Circuit (1 kHz, Half Rated Power)

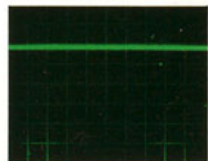

Distortion Waveform without New Linear Transfer Circuit (1 kHz, Half Rated Power)

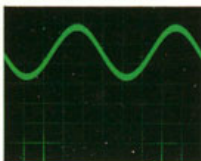

Selectable MM Cartridge Load Capacitance

A fact about moving magnet (MM) phono cartridges that is given too little attention in modern audio preamplifiers is that their high-end frequency response can vary considerably depending on the capacitive load presented to the cartridge by the preamplifier's phono inputs. This means that the user must specifically choose a cartridge that matches his amplifier's input capacitance in order to achieve the best possible reproduction quality. The C-50 eliminates this performance limitation by providing switchable 100 pF, 220 pF or 330 pF load capacitances (all at 47 k-ohms) that will provide optimum matching with just about any moving magnet cartridge available. The C-50 phono load selector also features a 100 ohm position for use with high-output moving-coil cartridges.

ERE (Extended Rolloff Equalizer)

With the vast improvements in overall amplifier performance, the time has come to provide an RIAA equalizer capable of equally fine performance. Today's low-level flat-response amplifiers easily achieve virtually distortion-free response up to 100 kHz or more. Conventional RIAA equalizer amplifiers, however, come nowhere near this outstanding performance. The Yamaha Extended Rolloff Equalizer meets the modern performance standards by eliminating phase variation beyond the range where conventional equalizers begin to deviate from the RIAA curve. This type of extended equalizer

accuracy was previously impossible to achieve because of high-frequency instability limitations. The Yamaha ERE completely eliminates this instability while providing an accurately extended high-frequency curve, permitting greater reproduction precision than has ever been possible.

The Yamaha ERE circuit makes a difference in phono reproduction that you can hear. And it's a difference you'll really appreciate because you'll discover nuances and subtleties in the music on your favorite records that you may never have heard before.

Rec Out Selector

This unique Yamaha feature permits simultaneous monitoring and recording of two different sources. For example, you can set the Rec Out selector to Phono and the Input selector to Tuner, then settle back to listen to your favorite radio program while simultaneously taping a friend's record.

4-Gang Volume Control

In most preamplifiers, signal-to-noise ratio deteriorates as volume is reduced because the amplifier's residual noise level becomes proportionately larger in relation to the audio signal as audio signal level is reduced. Yamaha's four-gang volume control, however, reduces the amplifier's residual noise as well as the audio signal level, thereby maintaining an extremely high signal-to-noise ratio all the way down to the lowest of low listening levels. No matter how low you set the volume, musical detail will not be obscured by unwanted noise.

Disc Direct Function

This advanced feature reflects Yamaha dedication to giving you nothing but the most natural sound reproduction quality available. When the Disc Direct function is engaged, the many input selector switch contacts as well as the entire tone control system are completely bypassed, coupling the output of the ERE phono equalizer amplifier directly to one of the C-50's high-performance flat amplifiers. This provides the purest, most straightforward signal path achieving the ultimate in disc reproduction accuracy.

Solenoid/Relay Function Switching

The C-50 features a unique light-touch function switching matrix that adds considerably to overall operating ease and convenience. This system has been made possible by the incorporation of a solenoid switching system for input selection (this helps to minimize signal lead length in the input stage thereby maximizing sound quality) and relay switching for the Disc Direct and Audio Muting functions. The relays used feature special gold-clad (not gold plated) contacts which ensure that absolutely no sound degradation occurs due to contact resistance.

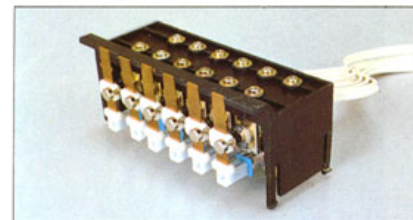

Other Features

- *Dual AUX terminals
- *Flip-down control cover
- *Switchable 15 Hz subsonic filter
- *Phono 1/2 selector
- *Stereo/Mono mode selector
- *Optional EIA rack mount adaptors

Yamaha Power Amplifiers: Revolutionary Technology

BEHIND YAMAHA'S SUPERIOR PERFORMANCE

The Power Amplifier as a "Music Energizer"

The music signal that reaches the inputs of a power amplifier in a conventional audio chain has usually been switched, equalized, response-tailored, filtered and voltage-amplified to a limited degree in the preamplifier and other pre-power stages, but it is still nowhere near powerful enough to drive a pair of speakers. It is the power amplifier's job to "energize" this low-level music signal (current amplification) to a level at which a pair of stereo speakers can be driven to satisfactorily high sound pressure levels. Naturally, this task of making the music signal "bigger" must be accomplished without altering the shape of the music signal in any way—i.e. without adding distortion. Two of the most important factors in achieving the highest power amplification quality are:

1. Device Linearity

This refers to the fact that all semiconductor devices (transistors, etc.) and even many static devices such



M-70

Zero Distortion Rule Circuit

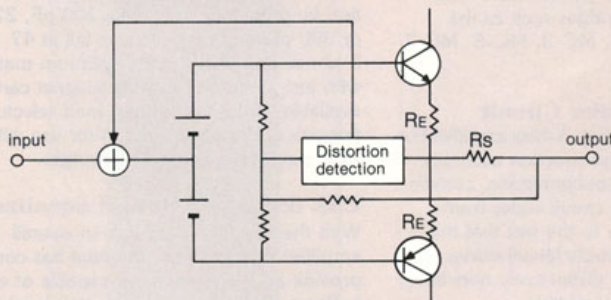

have a vast effect on ultimate reproduction performance.

2. Power

This refers to the amount of power the amplifier has available for power amplification. If the power capabilities of an amplifier are insufficient to handle the full dynamic

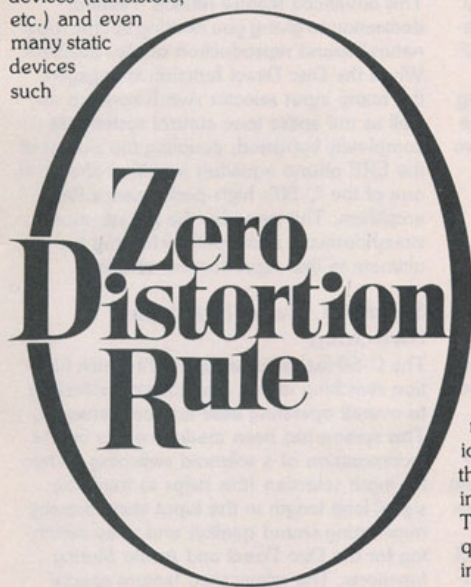

range of an input music source, for example, then clipping distortion occurring at high signal levels reduces the overall quality of the reproduced program. The two methods of overcoming power limitations are to provide far more power than will be required by the highest possible input signal levels, or to produce an extremely efficient amplifier that utilizes the greater portion of its available power for signal amplification.

This serious audio amplification problem requires the application of special circuit design in order to minimize the effect of device non-linearity on the music signal. Negative feedback is the most common example of a distortion-reducing circuit configuration. Also, the quality of individual components used in an amplifier circuit can

Yamaha Power Amplifier Firsts

Yamaha contributions to audio power amplification technology have had a considerable effect on the audio field. The legendary

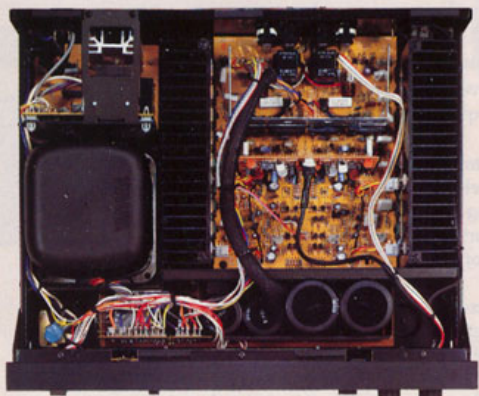

M-70 Interior

"X" Amplifier Power Level Switching Response

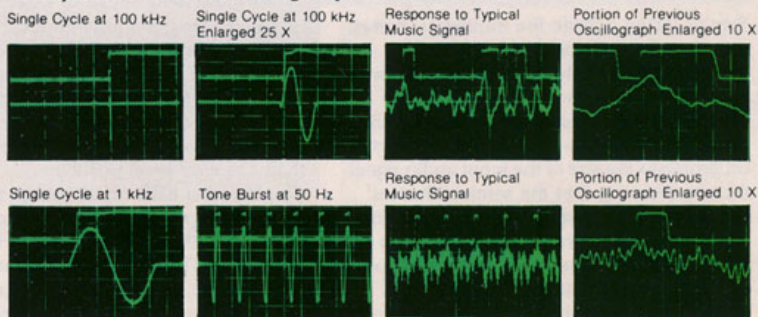



M-50

Yamaha B-1 power amplifier, for example, was the world's very first all-FET power amp—constructed with special Yamaha-developed power FETs of superlative quality. Even today, after several years of advancement in audio technology, the B-1 remains one of the finest power amplifiers available. The Yamaha M-2 power amplifier introduced the world to Linear Transfer Bias circuitry in the power output stage. This outstanding innovation essentially eliminated the long-standing power problem of crossover distortion. And in the same amplifier, Yamaha's top-quality high-ft power transistors reduced switching distortion to negligible levels. In terms of efficiency that resulted in superb audio performance, the incredible Yamaha B-6 power amplifier demonstrated that true high-performance, high-power amplifiers

don't have to be huge, power consuming or formidably expensive, and that it is possible to produce a power amplifier capable of supporting the exceptionally broad dynamic range and source accuracy available with today's direct cut and digitally recorded discs. The new Yamaha M-70 and M-50 stereo power amplifiers outperform even these illustrious forebearers, attaining new, unprecedented heights in audio power amplification.

TOP-PERFORMANCE TECHNOLOGY IN THE NEW M-70 AND M-50 POWER AMPLIFIERS

Although modern audio reproduction technology has succeeded in reducing the

distortion inherent in amplifier systems to more or less negligible levels, a disturbing amount of distortion still remains to plague the quest for absolute music reproduction accuracy. Audio designers have been able to approach the "zero distortion" line, coming a little closer with each new development, but never reaching the ultimate goal. The remarkable new Zero Distortion Rule (ZDR) power amplifier stage featured in the M-70 and M-50 attacks this problem by negating the unavoidable distortion or non-linearity inherent in all "elements"—resistors, capacitors, transistors,

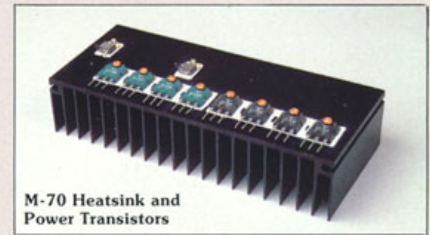

M-70 Heatsink and Power Transistors

etc.—rather than trying to reduce the inherent non-linearity itself. The result is that zero distortion has actually been achieved within the Zero Distortion Rule output stage. In fact, it is theoretically possible with the Zero Distortion Rule amplifier to cross the elusive zero distortion line and enter the realm of negative distortion. In terms of efficiency, the M-70 offers a power supply and amplification system similar to those that made the B-6 a star performer among power amplifiers. The M-50 features the same power supply concept. Overall, the M-70 and M-50 provide new, outstanding power performance, placing them in a position of clear superiority when it comes to pure, precise audio reproduction.

M-70/M-50 Slew Rate and Distortion Waveform

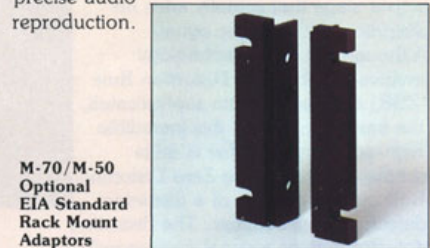
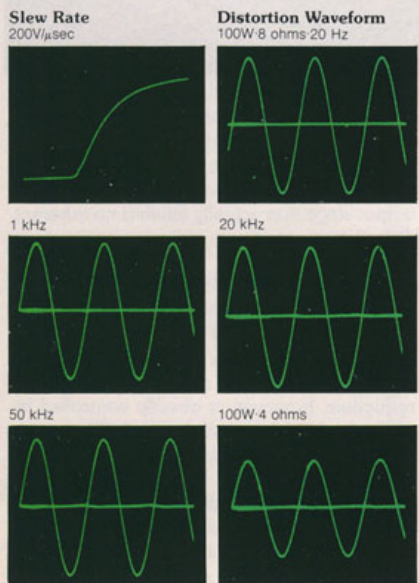

M-70/M-50
Optional
EIA Standard
Rack Mount
Adaptors



"X" Power Supply Triac and Trigger IC

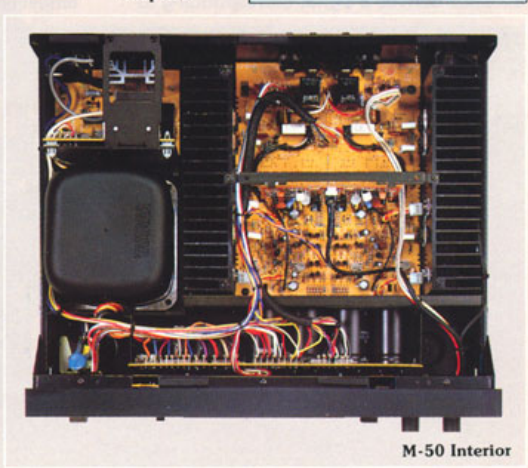

M-50 Interior

M-70 Natural Sound Stereo Power Amplifier



The Pure Zero Distortion Rule Sound

Here, at last, is a power amplifier output stage that actually adds no distortion to the music signal. Although the actual technology involved in the Zero Distortion Rule (ZDR) amplifier is quite sophisticated, the basic principle of this incredible high-accuracy amplifier is quite simple. Essentially the Zero Distortion Rule system consists of a distortion detector and a summer. The distortion detector derives a signal corresponding to

Zero Distortion Rule Circuit

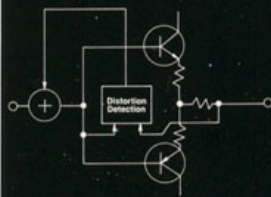

A: No ZDR applied. Desired signal plus distortion waveform

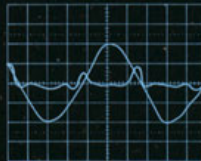

B: Normal application of ZDR. Distortion waveform cancelled.

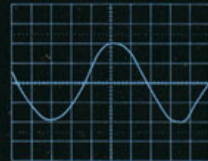

C: Deliberate over-application of ZDR. Negative image of original distortion waveform.

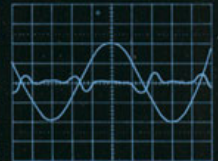

any distortion products originating in the amplifier itself, and the summer adds this signal back into the original audio/distortion signal—out of phase with the original signal. This effectively cancels the distortion signal, leaving the audio signal intact and virtually distortion-free. Of course, this system has no effect on distortion generated within the power amplifier itself. From the above description we can see that if the derived out-

were somehow made larger than the original distortion signal, summing these signals would actually result in a negative distortion product. With this ingenious system, it has become possible to produce a power output stage that actually exhibits no inherent distortion.

Zero Distortion Rule vs. Negative Feedback

Negative feedback (NFB) is the most commonly used means for reducing distortion in audio amplifiers. The amount of distortion reduction, however, is directly controlled by the amount of feedback applied. This means that in order to reduce distortion to zero, infinite feedback must be applied. Obviously, it is physically impossible to create infinite negative feedback, and therefore also impossible to achieve zero distortion by this method. Increasing application of negative feedback

Block Diagram

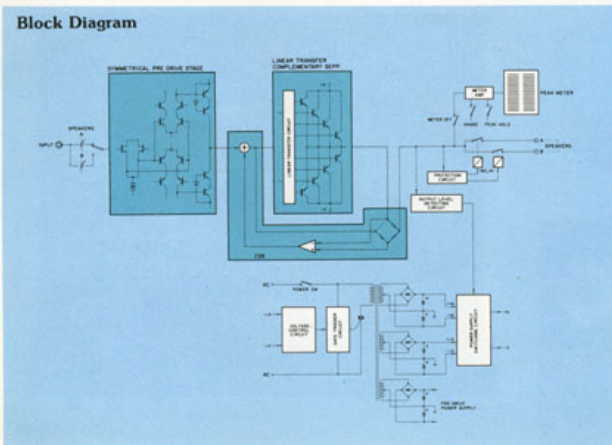

can only approach the zero distortion ideal, while Zero Distortion Rule actually permits crossing the zero distortion line and creating

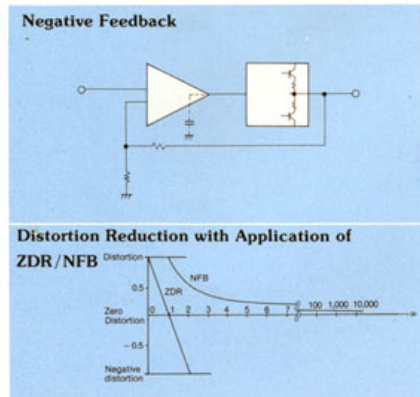

negative distortion, making it theoretically possible to completely eliminate distortion.

Zero Distortion Rule vs. Feed Forward

The feed forward system of distortion reduction attempts to cancel distortion by adding an inverted distortion signal to the audio signal at the amplifier's output where signal power levels are high. This means that expensive, high-power feed forward circuitry is required, and overall power efficiency is extremely low. Also, the high-power feed forward amplifier required can actually add unwanted distortion.

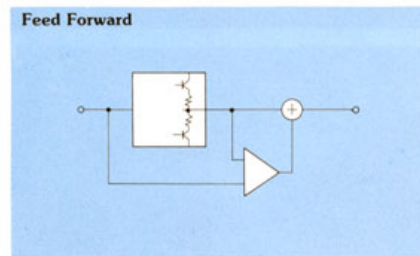

Zero Distortion Rule performs its distortion cancellation at the amplifier's inputs, thereby eliminating the power problem. And since the Zero Distortion Rule circuit is essentially concerned only with low-level signals, it cannot add any distortion of its own.

Linear Transfer Bias and the "X" Amplifier

In addition to the Zero Distortion Rule system, the M-70 features Linear Transfer Bias circuitry and Yamaha's remarkable "X" Power Amplifier system. The Linear Transfer Bias circuit minimizes the problem of crossover distortion due to non-uniform linearity between the power transistors in a push-pull power stage. By applying precisely calibrated bias to each transistor in the M-70's cascaded push-pull power circuit and thereby staggering the operating point of each, a perfectly linear composite transfer characteristic is achieved, ensuring negligible crossover distortion levels.

The "X" Power Amplifier achieves extremely high amplification efficiency by switching the power stage power supply voltage between two voltage levels—low and high—according to the size of the signal being processed. For average signal levels, for example, the lower supply voltage is used, while the high

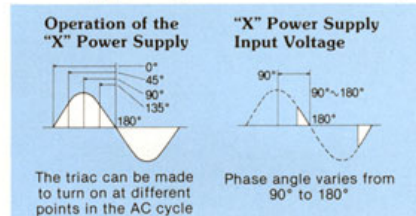

supply voltage is instantaneously switched in whenever a high-level music peak is detected. This system eliminates the power wasted in the form of heat that conventional systems must dissipate with large, finned "heat sinks". The fact that the "X" Power Amplifier permits true high-power music amplification with maximum efficiency and minimum heat generation means that the entire amplifier circuit operates under optimum conditions at all times, ensuring the cleanest, most accurate music reproduction. The unbeatable combination of the Linear Transfer Bias circuit, "X" Power Amplification, and Zero Distortion Rule amplifier design results in outstanding low-distortion power performance and incredible power efficiency for unmatched reproduction precision and exceptionally natural sound quality.

"X" Power Purity

The concept of "pure power" is extremely important in achieving the highest power amplifier performance. That is, the power source that supplies power to the actual power amplification circuitry must be capable of providing extremely stable power, and at the same time supply as much power as the amplifier circuitry demands without "running out".

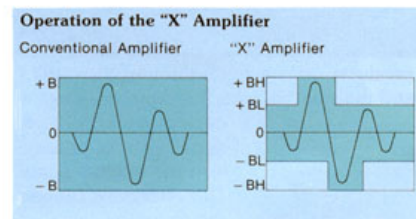

The Yamaha "X" power supply easily meets the above requirements, with greater efficiency and power capacity than any other power system of its size or weight. In principle, the "X" power supply controls the amount of power fed from the AC line to the power supply to precisely match the amount of power consumed by the amplifier at any given instant. Whether the amplifier requires only a small amount of power for average music levels, or a large amount for high-level music peaks, the "X" power supply feeds precisely the required amount of power to the amplifier circuitry. Naturally, this means

that all the supplied power is consumed, achieving remarkable power efficiency. In terms of stability, the "X" power supply affords exceptionally high regulation capabilities. Line supply voltage variations of as much as $\pm 10\%$ have no effect on the "X" power supply's output voltage, and resistance to influence by load variations is similarly high. The "X" power supply system permits the amplifier circuitry to operate at optimum efficiency under optimum conditions at all times, ensuring that the music source is reproduced with maximum accuracy.

Speaker Level Controls

In addition to speaker A/B selectors that permit one-touch selection of two sets of stereo speakers, the M-70 features independent level controls for the left and right speakers in two stereo pairs. That is, you have independent left and right speaker level controls for speaker pair "A", and left and right level controls for speaker pair "B". These controls let you independently set the maximum power level that will be sent to the respective pair of speakers, protecting low-power-capacity speakers from excessive power levels, or matching the output level of two sets of speakers of different efficiency. Independent control over left and right speaker level lets you preset the balance of your system for optimum stereo imaging depending on the positioning of your speakers and the acoustics of your listening room.

20-LED Peak Power Output Meters

These bright, attractive power meters let you see at a glance just how much power is actually being fed to your speakers. This makes it easier to determine the proper setting of the speaker level controls to prevent speaker breakup distortion or burnout due to power levels exceeding the speakers' capacity. For easier reading, these advanced meters feature dual switchable ranges and a peak hold function that displays the highest encountered power levels for considerably longer than the overall meter fall time.

Output Power vs. Total Harmonic Distortion

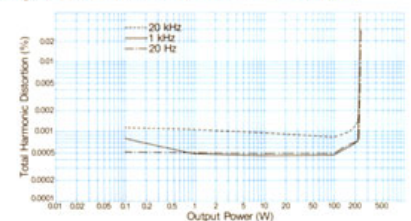

Frequency vs. Total Harmonic Distortion

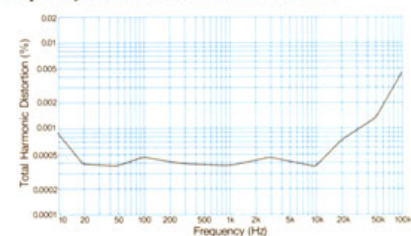

M-50 Natural Sound Stereo Power Amplifier



Introducing the Pure Zero Distortion Rule Sound

Here, at last, is a power amplifier output stage that actually adds *no distortion* to the music signal. Although the actual technology involved in the Zero Distortion Rule amplifier is quite sophisticated, the basic principle of this incredible high-accuracy amplifier is quite simple. Essentially the Zero Distortion Rule system consists of a distortion detector and a summer. The distortion detector derives a signal corresponding to any distortion

Zero Distortion Rule Circuit

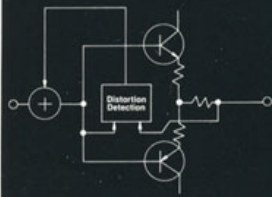

A: No ZDR applied. Desired signal plus distortion waveform

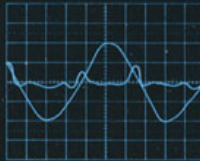

B: Normal application of ZDR. Distortion waveform cancelled.

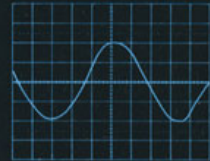

C: Deliberate over-application of ZDR. Negative image of original distortion waveform.

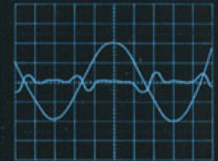

products originating in the amplifier itself, and the summer adds this signal back into the original audio/distortion signal—out of phase with the original signal. This effectively cancels the distortion signal, leaving the audio signal intact and virtually distortion-free. Of course, this system has no effect on distortion originating in the source signal, only on distortion generated within the power amplifier itself. From the above description we can see that if the derived out-of-phase distortion signal were somehow made

larger than the original distortion signal, summing these signals would actually result in a negative distortion product. With this ingenious system, it has become possible to produce a power output stage that actually exhibits *no inherent distortion*.

The Yamaha Zero Distortion Rule Amplifier vs. Negative Feedback and Feed Forward Systems

Negative feedback is the most commonly used means for reducing distortion in audio amplifiers. The amount of distortion reduction, however, is directly controlled by the amount of feedback applied. This means that in order to reduce distortion to zero, infinite feedback must be applied. Obviously, it is physically impossible to create infinite negative feedback, and therefore also impossible

Block Diagram

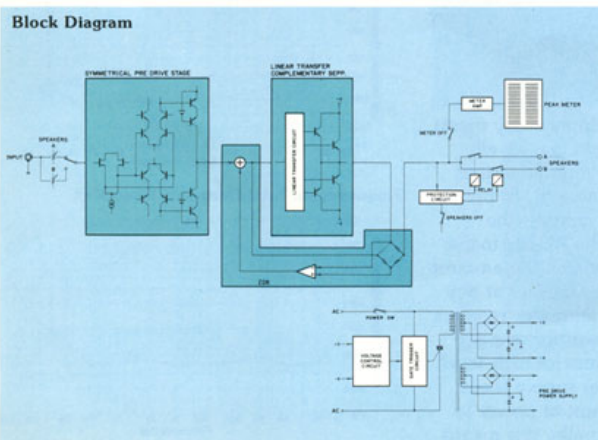

to achieve zero distortion by this method. Increasing application of negative feedback can only approach the zero distortion ideal, while ZDR actually permits crossing the zero

Negative Feedback

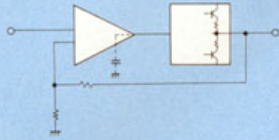

Distortion Reduction with Application of ZDR/NFB

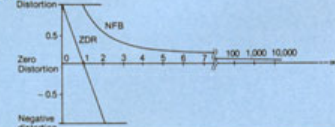

distortion line and creating negative distortion, making it theoretically possible to completely eliminate distortion.

The feed forward system of distortion reduction attempts to cancel distortion by adding an inverted distortion signal to the audio signal at the amplifier's output where signal power levels are high.

Feed Forward

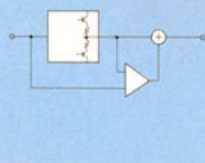

This means that expensive, high-power feed forward circuitry is required, and overall power efficiency is extremely low. Also, the high-power feed forward amplifier required can actually add unwanted distortion.

Zero Distortion Rule performs its distortion cancellation at the amplifier's inputs thereby eliminating the power problem. And since the ZDR circuit is essentially concerned only with low-level signals, it cannot add any distortion of its own.

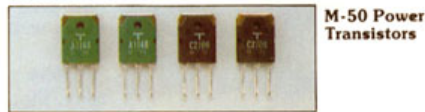

M-50 Power Transistors

Linear Transfer Bias Circuit

Another feature of the M-50 power stage is its Linear Transfer Bias circuitry. This unique bias system minimizes crossover distortion due to non-uniform linearity between the

Power output stage featuring Linear Transfer Bias

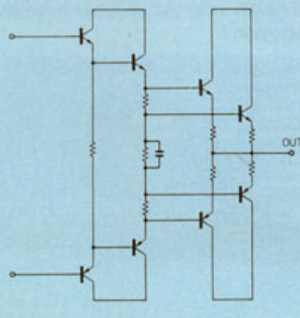

power transistors in a push-pull power stage. By applying precisely calibrated bias to each transistor in the M-50's cascaded push-pull power circuit and thereby staggering the operating point of each, a perfectly linear

Composite Transfer Characteristics without Bias



Composite (exponential) Transfer Characteristics

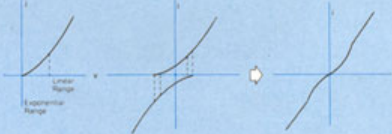

Composite (square) Transfer Characteristics



composite transfer characteristic is achieved, ensuring negligible crossover distortion levels. The unbeatable combination of the Linear Transfer Bias circuit and Zero Distortion Rule amplifier design results in outstanding low-distortion power performance and incredibly natural source reproduction.

"X" Power Purity

The concept of "pure power" is extremely important in achieving the highest power amplifier performance. That is, the power source that supplies power to the actual power amplification circuitry must be capable of providing extremely stable power, and at the same time supply as much power as the amplifier circuitry demands without "running out".

The Yamaha "X" power supply easily meets the above requirements, with greater efficiency and power capacity than any other power system of its size or weight. In principle, the "X" power supply controls the amount of power fed from the AC line to the power

"X" Power Supply Line/Load Regulation

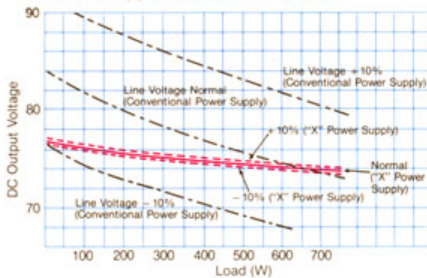

supply to precisely match the amount of power consumed by the amplifier at any given instant. Whether the amplifier requires only a small amount of power for average music levels, or a large amount for high-level music peaks, the "X" power supply feeds precisely

the required amount of power to the amplifier circuitry. Naturally, this means that all the supplied power is consumed, achieving remarkable power efficiency.

In terms of stability, the "X" power supply affords exceptionally high regulation capabilities. Line supply voltage variations of as much as $\pm 10\%$ have no effect on the "X" power supply's output voltage, and resistance to influence by load variations is similarly high. The "X" power supply system permits the amplifier circuitry to operate at optimum efficiency under optimum conditions at all times, ensuring that the music source is reproduced with maximum accuracy.

Speaker Level Controls

In addition to a speaker A/B selector that permits one-touch selection of two sets of stereo speakers, the M-50 features speaker A and B level controls. These controls let you independently set the maximum power



level that will be sent to the respective pair of speakers, protecting low-power-capacity speakers from excessive power levels, or matching the output level of two sets of speakers of different efficiency.

20-LED Peak Power Output Meters

These bright, attractive power meters let you see at a glance just how much power is actually being fed to your speakers. This makes it easier to determine the proper setting of the speaker level controls to prevent speaker breakup distortion or burnout due to power levels exceeding the speakers' capacity.

Output Power vs. Total Harmonic Distortion

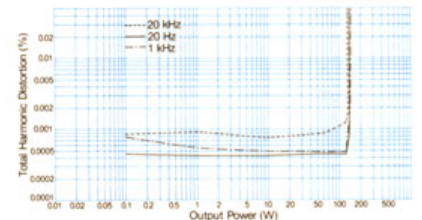

Frequency vs. Total Harmonic Distortion

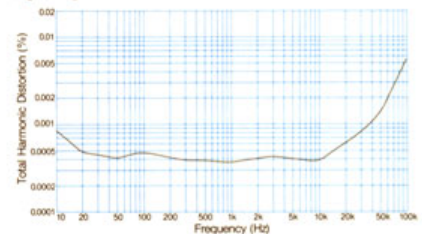

CSL Microcomputer and Associated ICs

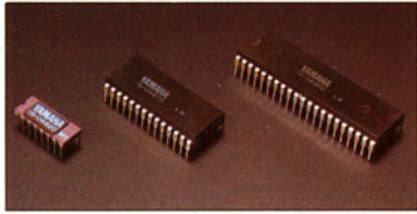

RF Servo Gain Control

The T-70 is exceptionally resistant to inter-modulation distortion caused by strong interfering stations thanks to a unique Yamaha RF Servo Gain Control system. When an interfering station is detected, the RF Servo Gain Control turns on automatically

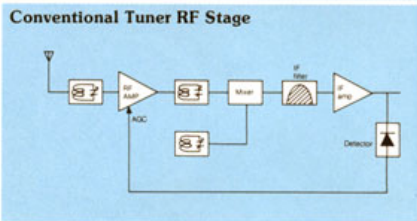
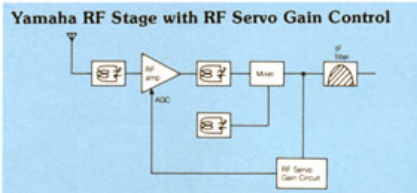

to reduce RF gain by a carefully controlled amount, effectively avoiding this kind of interference. When no interfering signal is present, the T-70 automatically sets the normal RF gain for optimum sensitivity, signal-to-noise ratio and sound quality.

Ultra-Linear Direct FM Detector

This high-performance circuit offers a simpler, cleaner signal path as well as improved linearity compared to even the latest pulse-count detector systems. The outstanding low-noise, low-distortion performance provided by this unique Yamaha circuit ensures that the music signal reaches the multiplex stereo

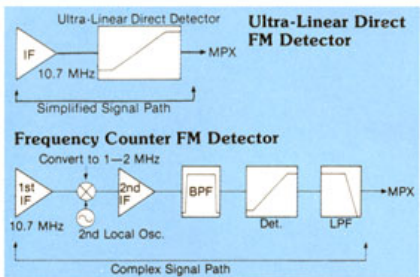

Ultra-Linear Direct FM Detector Square-Wave Response

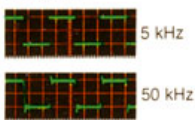

Frequency Counter FM Detector Square-Wave Response

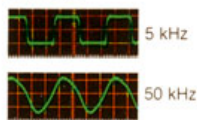

decoder stage with no distortion added from the time it reached the tuner's antenna.

Real-Time Direct CMOS DC NFB PLL Multiplex Demodulator

Conventional stereo demultiplexing systems involve turning semiconductor analog switches on and off at a 38 kHz rate. Switching distortion can be a problem, however, since the switches have a finite switching time and are located in the signal path.

The T-70 completely overcomes this problem by using extremely high speed CMOS switches located in the negative feedback loop of a high slew rate DC amplifier. The

Real-Time Direct MPX Demodulator Switching Waveform

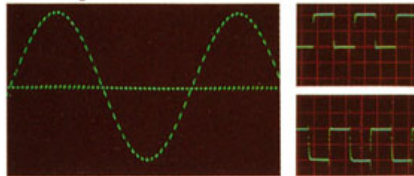

MPX Demodulator Switching Waveform of Frequency Counter Tuner

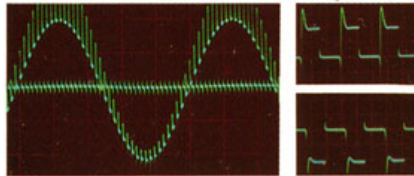

Real-Time Direct MPX Demodulator

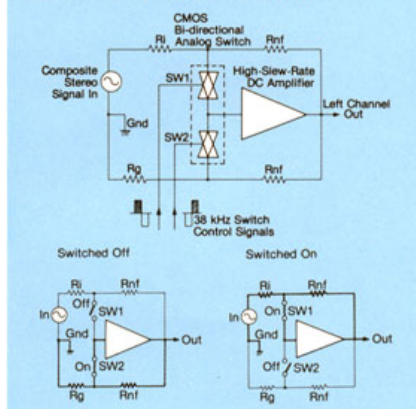

resulting demodulator offers excellent stereo separation, low harmonic and intermodulation distortion, and exceptional transient response for the most natural FM stereo reproduction.

AM/FM 10-Station Random Access Preset Tuning

Up to 10 AM and FM stations can be programmed into the T-70 memory for instant one-touch tuning. Unlike many preset tuning systems which may have 5 preset memories specifically for AM and 5 more for FM, the T-70 random-access system lets you preset any combination of AM and FM stations in any order up to a total of 10. You can even program all FM or all AM stations if you like.

This is possible because the T-70 memory not only stores the stations's frequency, but the band (AM or FM) as well. If you program 10 stations with your favorite ones first, you'll be able to quickly call them out in order without having to switch back and forth between the AM and FM bands. No other tuner, synthesizer or otherwise, has ever been produced that is easier to use and listen to than the Yamaha T-70.

Initial Station Set

In addition to the 10-station random access preset memory system, an initial station set function is provided which lets you pre-program any station to be tuned in every time power to the tuner is switched on. Preset your favorite station using this function, then whenever you turn the T-70 on you're precisely tuned in—the perfect feature for timer recording from FM broadcasts. Additionally, all the T-70's memory is non-volatile. This means that it will not be cleared or erased even if power to the tuner is completely cut off. And there's no time limit to unpowered memory storage as there is with backup battery and capacitor supplies.

Other Features

- Auto DX
- Anti-Interference PLL system
- Tracking Type Pure Pilot Canceller
- Pushbutton auto-search tuning
- Manual single-step tuning
- High-Q low-impedance AM loop antenna
- Selectable AM selectivity
- Built-in recording calibration oscillator
- Signal Quality indicator

Optional EIA Standard Rack Mount Adaptors



FM THD vs. Modulation Frequency

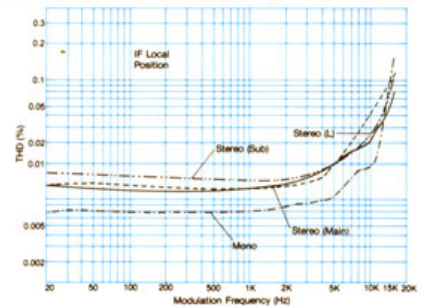

FM Alternate Selectivity

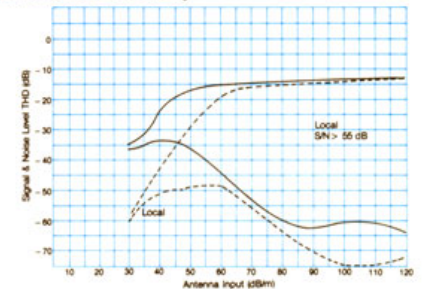

The Top-Line Systems—Reaching for

Yamaha technology lets you hear the music as you've never heard it before

C-50: Stereo Control Amplifier
M-50: Stereo Power Amplifier
T-70: AM/FM Stereo Tuner
PX-3: Linear Tracking Stereo Turntable
K-960: Stereo Cassette Deck
NS-1000M: 3-Way Speaker System



the Ultimate in Sound Reproduction.

Yamaha's finest – the peak of perfection in audio quality

C-70: Stereo Control Amplifier
M-70: Stereo Power Amplifier
T-70: AM/FM Stereo Tuner
PX-2: Linear Tracking Stereo Turntable
K-960: Stereo Cassette Deck
NS-1000M: 3-Way Speaker System



To Complete Your Top Quality Yamaha System



PX-2 *Natural Sound Linear Tracking Turntable*

The PX-2 employs a highly sophisticated linear tracking mechanism which enables it to actually achieve the linear tracking ideal: precisely recreating the movement of the head which originally cut the record. Truly accurate, *faithful* sound reproduction has finally become possible. This mechanism, combined with Yamaha's symmetrically balanced, optimum mass, straight tonearm and a quartz-lock PLL-servo direct drive system, provides unparalleled turntable performance. Operating convenience is also far above average, with two-speed tonearm positioning, one-touch disc size selection/play initiation, repeat function, and IC logic controls.

- S/N ratio: 80 dB ● Wow & flutter: 0.01%
- Dimensions (W x H x D): 493 x 156 x 428 mm ● Weight: 17 kg



PX-3 *Natural Sound Linear Tracking Turntable*

Yamaha technology allows the PX-3 to take full advantage of the linear tracking design to deliver truly natural music reproduction. The Yamaha linear tracking system virtually eliminates tracking error and inside force for greatly reduced distortion, minimum crosstalk, and exceptional stereo imaging. Like the PX-2, the PX-3 also incorporates a straight, perfectly symmetrical, optimum mass tonearm and quartz-lock PLL-servo direct drive system. This turntable is a pleasure to operate, as well, thanks to a specially developed Yamaha logic LSI which provides extensive control convenience and flexibility. Operation is fully automatic, with two-speed tonearm positioning and repeat capabilities also included.

- S/N ratio: 77 dB ● Wow & flutter: 0.015%
- Dimensions (W x H x D): 469 x 149 x 428 mm ● Weight: 12 kg



MC-1X/MC-1S *Natural Sound Moving Coil Cartridges*

The MC-1X moving coil cartridge with integral headshell and the MC-1S universal type moving coil cartridge are specifically designed to reproduce every detail of the original sound exactly as it was recorded. To achieve this goal, the Yamaha cartridge design team developed a pure beryllium tapered pipe cantilever. It is extremely light, but rigid, so it responds precisely to each minute modulation cut into the record's grooves. Other beryllium benefits are minimized sound coloration due to cantilever resonance and outstanding trackability for

low-distortion reproduction. Further design points unique to these cartridges are a yokeless dual differential magnetic circuit with samarium cobalt magnets, and a "root wing" coil suspension system. The result is a magnificent cartridge which has been highly praised by audio critics the world over.

- Frequency response: 10–20,000 Hz (capability: 60 kHz) ● Channel separation: more than 28 dB (1 kHz) ● Weight: 18.5 g (MC-1X); 7.8 g (MC-1S)

K-960 *Natural Sound Stereo Cassette Deck*

When Yamaha's audio engineers decided to design a truly high performance cassette deck, they didn't overlook any details. First, they chose a two-motor transport, but re-designed the system to eliminate the instabilities of conventional two-motor designs. For the rec/playback head, they used the finest material available—Sendust—formed by a unique Yamaha process for absolute purity. With 5-layer core lamination and low impedance design, this head is superior to ordinary types in all respects. And for the best possible dynamic range and signal-to-noise ratio, the dbx** system was included. Add to this features like fine bias adjust, focus switch, metal compatibility and Dolby* NR, and the result is the K-960—a triumph of cassette deck engineering.

- Silver Model also available ● S/N ratio: 100/60 dB (dbx on/off, metal tape)
- Wow & flutter: 0.028% ● Dimensions (W×H×D): 435×140.8×303.5 mm
- Weight: 8 kg



*TM Dolby Laboratories Licensing Corp. **dbx is a trademark of dbx incorporated.

NS-1000/1000M *Natural Sound Speaker System*

Used as a monitor speaker in recording studios and as a reference speaker in test labs around the world, the NS-1000/1000M has made a name for itself as one of the finest speakers available in this crowded segment of the audio market. Utilizing Yamaha's unique pure vapor-deposition beryllium domes for the midrange and treble drivers, and drawing on Yamaha skill in woodworking, metal casting, and acoustic design, this speaker is special in every way. Still another reason for its well-deserved reputation is the extensive testing which each speaker undergoes, including listening tests by our "golden-eared" experts. This handsome speaker is available in a deluxe ebony cabinet (NS-1000) or professional monitor design (NS-1000M).

- Maximum input capacity: 100 W ● Sound pressure level: 90 dB/W/m
- Frequency response: 40—20,000 Hz ● Woofer: 30-cm cone ● Midrange 8.8-cm beryllium dome ● Tweeter: 3-cm beryllium dome
- Dimensions (H×W×D): 710×395×349 mm (NS-1000); 675×375×326 mm (NS-1000M) ● Weight: 39 kg (NS-1000); 31 kg (NS-1000M)



NS-1000

NS-1000M

YH-1000 *Natural Sound Stereo Headphones*

These headphones feature Yamaha's exclusive Orthodynamic Design, a concept radically different from conventional dynamic or electrostatic types. Instead of an ordinary voice coil and diaphragm, it uses an ultra thin, low mass, polyester film diaphragm, sandwiched by a pair of powerful disc magnets. The voice coils are photo-etched on the surface of the diaphragm. The performance that results is marked by smooth, even response over the entire audible frequency

range, low distortion, and clear imaging. The YH-1000 is a delight to wear, also: the earcups use a supra-aural design which eliminates listening fatigue, and the lightweight design, soft leather strap, and height and tilt adjustment ensure comfort over long hours of use.

- Frequency response: 20—20,000 Hz ● Output SPL: 103 dB/mV ● Weight (without cord): 500 g



Specifications

	C-70	C-50
Input Sensitivity/Impedance		
Phono MC	100 μ V/100 ohms	100 μ V/100 ohms
Phono MM	2.5 mV/100 ohms	2.5 mV/100 ohms
	2.5 mV/47 k-ohms 100 pF	2.5 mV/47 k-ohms 100 pF
	2.5 mV/47 k-ohms 220 pF	2.5 mV/47 k-ohms 220 pF
	2.5 mV/47 k-ohms 330 pF	2.5 mV/47 k-ohms 330 pF
Aux/Tape/Tuner	150 mV/47 k-ohms	150 mV/47 k-ohms
Input Sensitivity (New IHF)		
Phono MC	33 μ V	33 μ V
Phono MM	0.83 mV	0.83 mV
Aux/Tape/Tuner	50 mV	50 mV
Maximum Input Level (1 kHz, 0.01% THD/New IHF)		
Phono MC	13 mV/11 mV	8.5 mV/8 mV
Phono MM	300 mV/260 mV	220 mV/220 mV
Output Level/Impedance		
Rec Out	150 mV/470 ohms	150 mV/470 ohms
Pre Out	1.5 V/47 ohms	1.5 V/47 ohms
Maximum Output Level (20 to 20,000 Hz, 0.1% THD)		
Pre Out	10 V	10 V
Headphone Maximum Output Level/Impedance (1 kHz, 0.01% THD, Output Impedance 68 ohms)		
	0.48 V/8 ohms	0.45 V/8 ohms
	4.5 V/100 ohms	4.0 V/100 ohms
Frequency Response (Aux/Tape/Tuner to Sp Out)		
	5 to 100,000 Hz +0, -0.5 dB	DC to 100,000 Hz +0, -0.5 dB
RIAA Deviation		
(Phono MC)	20 to 20,000 Hz \pm 0.2 dB	20 to 20,000 Hz \pm 0.2 dB
(Phono MM)	10 to 100,000 Hz \pm 0.3 dB	10 to 100,000 Hz \pm 0.5 dB
Total Harmonic Distortion		
(Phono MC to Rec Out 3 V output)	0.001%	0.002%
(Phono MM to Rec Out 3 V output)	0.001%	0.001%
(Aux/Tape/Tuner to Pre Out 5 V output, Tone Switch Off)	0.001%	0.001%
Intermodulation Distortion (Aux/Tape/Tuner 5 V output, Tone Switch Off)		
	0.002%	0.002%
Signal-to-Noise Ratio (IHF-A-Network)		
Phono MC (500 V, Input Shorted)	90 dB	90 dB
Phono MM (5 mV, Input Shorted)	94 dB	93 dB
Aux/Tape/Tuner (Tone Switch Off)	105 dB	105 dB
Signal-to-Noise Ratio (New IHF)		
Phono MC	80 dB	80 dB
Phono MM	82 dB	81 dB
Aux/Tape/Tuner	104 dB	96 dB
Residual Noise (IHF-A-Network)	1.8 μ V	2.5 μ V
Channel Separation Phono MM/Aux, Tape (5.1 k-ohms, Input Shorted)		
40 Hz, 1 kHz, 10 kHz	85 dB/100 dB, 80 dB/70 dB, 70 dB/60 dB	85 dB/85 dB, 80 dB/70 dB, 68 dB/53 dB
Parametric Equalizer Characteristics		
Frequency Control (Low)	31.5 to 800 Hz	—
(High)	800 to 20,000 Hz	—
Level Control (Low/High)	\pm 12 dB	—
Bandwidth Control (Low/High)	Q: 0.3 to 3.0	—
Filter Characteristics		
Low (Subsonic)	15 Hz, -12 dB/oct	15 Hz, -12 dB/oct
High	10 kHz, -12 dB/oct	—
Audio Muting	-20 dB	-20 dB
Tone Control Characteristics		
Bass (boost/cut)	—	\pm 10 dB
Treble (boost/cut)	—	\pm 10 dB
Turnover Frequency		
Bass	—	100 to 500 Hz
Treble	—	1 to 5 kHz
GENERAL		
Power Supply	Matched to supply voltage and frequency of each area	Matched to supply voltage and frequency of each area
Power Consumption	50 W	40 W
Dimension (W x H x D)	435 x 96.5 x 369 mm 17-1/8" x 3-3/4" x 14-1/2"	435 x 96.5 x 369 mm 17-1/8" x 3-3/4" x 14-1/2"
Weight	7.2 kg (15 lbs. 13 oz.)	6.8 kg (15 lbs.)

	M-70	M-50
Minimum RMS Output Power per Channel	200 Watts (8 ohms) from 20 to 20,000 Hz at no more than 0.002% Total Harmonic Distortion	120 Watts* (8 ohms) from 20 to 20,000 Hz at no more than 0.002% Total Harmonic Distortion *Europe, Britain and Australia: 110 Watts
	250 Watts (4 ohms) at 1 kHz, Clipping Power	200 Watts (4 ohms) at 1 kHz, Clipping Power
Power Bandwidth		
8 ohms, Half Rated Power	10 to 100,000 Hz (0.02% THD)	10 to 100,000 Hz (0.02% THD)
Input Sensitivity/Impedance		
8 ohms, Rated Power	1.41 V/25 k-ohms	1.1 V/25 k-ohms
Frequency Response		
8 ohms, Half Rated Power, 100 kHz	-0.5 dB	-0.5 dB
Signal-to-Noise Ratio		
IHF-A-Network	124 dB	122 dB (Europe, Britain and Australia: 121 dB)
Total Harmonic Distortion		
8 ohms, Half Rated Power		
20 Hz/1 kHz/20 kHz/50 kHz/100 kHz	0.0005%/0.0005%/0.001%/0.003%/0.006%	0.0005%/0.0005%/0.001%/0.004%/0.01%
Intermodulation Distortion		
8 ohms, Half Rated Power, 50 Hz: 7 kHz = 4:1	0.002%	0.002%
Channel Separation (Input Shorted)		
8 ohms, Half Rated Power		
20 Hz/1 kHz/20 kHz	100 dB/95 dB/70 dB	100 dB/95 dB/70 dB
Damping Factor (8 ohms, 1 kHz)	Better than 200	Better than 200
Slew Rate (Sp out)	200 V/μsec.	200 V/μsec.
Power Supply	Matched to supply voltage and frequency of all area	Matched to supply voltage and frequency of all area
Power Consumption		
U.S.A. and Canada	600 W/1,200 VA	350 W/800 VA
Europe, Britain and Australia	900 W	550 W
Other Areas	550 W	200 W
Dimensions (W x H x D)	435 x 133 x 380 mm (17-1/8" x 5-1/4" x 15")	435 x 133 x 380 mm (17-1/8" x 5-1/4" x 15")
Weight	13.7 kg (30 lbs. 3 oz.)	11.8 kg (26 lbs.)

			T-70	
FM SECTION			Stereo	Local 0.04%, DX 0.6%
Tuning Range	87.8 to 108 MHz		Stereo Separation	
50 dB Quieting Sensitivity (IHF)			50 Hz	Local 60 dB, DX 28 dB
Mono (DX)	3.0 μV (14.7 dBf)		1 kHz	Local 60 dB, DX 28 dB
Stereo (DX)	32 μV (35.3 dBf)		10 kHz	Local 50 dB, DX 25 dB
Usable Sensitivity			Frequency Response	
Mono (98 MHz, 30 dB Quieting)			50 Hz to 10 kHz	±0.3 dB
	1.2 μV (300 ohms) 6.8 dBf		30 Hz to 15 kHz	+0.3, -0.5 dB
	0.6 μV (75 ohms) 6.8 dBf		Subcarrier Product Ratio	65 dB
DIN Mono (S/N 26 dB)	1.2 μV		Auto-DX Threshold	40 μV (37.3 dBf)
DIN Stereo (S/N 46 dB)	35 μV		AM SECTION	
Image Response Ratio (98 MHz)	85 dB		Tuning Range	516 to 1,614 kHz
IF Response Ratio (98 MHz)	100 dB		Usable Sensitivity (IHF)	10 μV
Spurious Response Ratio (98 MHz)	100 dB		Selectivity	Local 17 dB, DX 27 dB
AM Suppression Ratio (IHF)	65 dB		Signal-to-Noise Ratio	50 dB
Capture Ratio (IHF)	Local 1.2 dB, DX 2.5 dB		Image Response Ratio (1,000 kHz)	45 dB
Alternate Channel Selectivity	IHF Local 25 dB, DX 85 dB		Spurious Response Ratio	Better than 50 dB
	DIN Local 15 dB, DX 70 dB		Distortion (1 kHz)	0.3%
Signal-to-Noise Ratio (at 85 dBf)			AUDIO SECTION	
Mono	88 dB		Output Level/Impedance	
Stereo	83 dB		FM (100% mod. 1 kHz)	500 mV/2.2 k-ohms
DIN (Weighted) Mono	80 dB		AM (30% mod. 1 kHz)	150 mV/2.2 k-ohms
Stereo	76 dB		Rec Cal Signal (333 Hz:	
Distortion			Corresponding to 50%	
Mono	100 Hz	Local 0.02%, DX 0.05%	FM modulation)	250 mV/4.7 k-ohms
	1 kHz	Local 0.03%, DX 0.3%	GENERAL	
	6 kHz	Local 0.05%, DX 0.8%	Power Supplies	Matched to supply voltage and frequency of each area
Stereo	100 Hz	Local 0.04%, DX 0.6%	Power Consumption	12 W
	1 kHz	Local 0.04%, DX 0.6%	Dimensions (W x H x D)	435 x 72 x 320.5 mm (17-1/8" x 2-7/8" x 12-5/8")
	6 kHz	Local 0.06%, DX 1.2%	Weight	4.0 kg (8 lbs. 13 oz.)
Intermodulation Distortion (IHF)				
Mono	Local 0.03%, DX 0.3%			

Specifications subject to change without notice.



For details please contact:

SINCE 1887  **YAMAHA**
NIPPON GAKKI CO., LTD. HAMAMATSU, JAPAN